

Refrigerated container KOALA 495

20/01//2025 - Rev.2



ATP

600x400



Refrigerated container for the transport of products at temperature-controlled

- Brand: MELFORM
- Country of origin: ITALY
- Customs code: 84181080
- ATP Certificate
- Compatible with food contact
- Color: grey/blue
- Available in version basic, on wheels, feet
- Dual power supply: 12Vdc and 230Vac
- Technology: rotomoulding
- Warranty: 24 months
- Fully recyclable at the end of its operational life.

MANUFACTURING MATERIALS

| | | | |
|-------------------------|--|-----------------------------|---|
| Polyethylene | internal and external walls of the container and door; suitable for food contact | Polyurethane | insulating material between the walls of the container and the door, free of CFC and HCFC |
| Silicone rubber | gasket | Rubber and polyamide | wheels (rubber tread and polyamide core) |
| Galvanized steel | crankcase, wheel support | Stainless steel | handling handles, closing handle, rod inside the door |



Via Savigliano 34 - 12030 Monasterolo di Savigliano (CN) -ITALY
Phone +39 0172812600 - info@melform.com
www.melform.com

| Model | Product code | EAN code | Ext. dim. (mm) | Int. dim. (mm) | Capac. (L) | Wt (Kg) |
|--|--------------|---------------|----------------|----------------|------------|---------|
| Integrated cooling unit, static 0°C /+10°C basic | K495AFISDYM0 | 8022949210014 | 855x1285xh1195 | 625x850xh950 | 520 | 119 |
| Integrated cooling unit, static 0°C /+40°C basic | K495AFISDZM0 | 8022949197360 | 855x1285xh1195 | 625x850xh950 | 520 | 119 |
| Integrated cooling unit, ventilated -25°C /+10°C basic | K495AFIVBYM0 | 8022949209995 | 855x1285xh1195 | 625x850xh805 | 430 | 129 |
| Integrated cooling unit, ventilated -25°C /+40°C basic | K495AFIVBZM0 | 8022949210007 | 855x1285xh1195 | 625x850xh805 | 430 | 129 |
| Integrated cooling unit, static 0°C /+10°C on wheels | K495AFISDYM1 | 8022949208806 | 855x1285xh1360 | 625x850xh950 | 520 | 125 |
| Integrated cooling unit, static 0°C /+40°C on wheels | K495AFISDZM1 | 8022949208592 | 855x1285xh1360 | 625x850xh950 | 520 | 125 |
| Integrated cooling unit, ventilated -25°C /+10°C on wheels | K495AFIVBYM1 | 8022949208790 | 855x1285xh1360 | 625x850xh805 | 445 | 135 |
| Integrated cooling unit, ventilated -25°C/+40°C on wheels | K495AFIVBZM1 | 8022949207205 | 855x1285xh1360 | 625x850xh805 | 445 | 135 |

DIMENSIONAL DIAGRAM (mm)

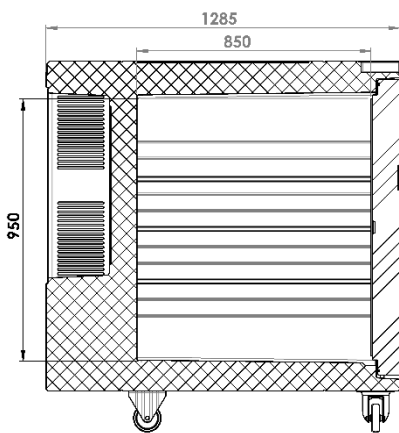

Koala 495 static

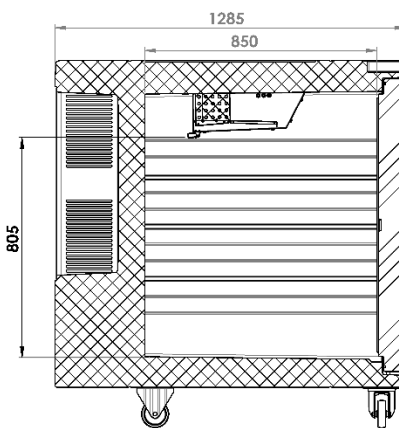
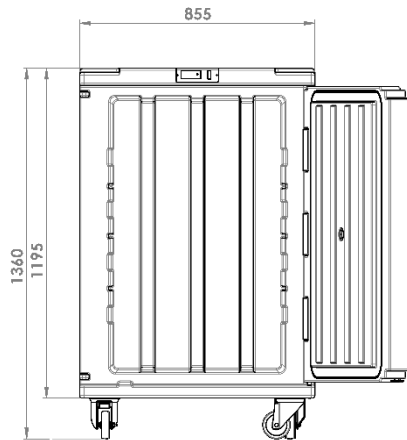
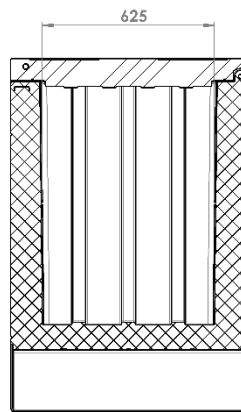



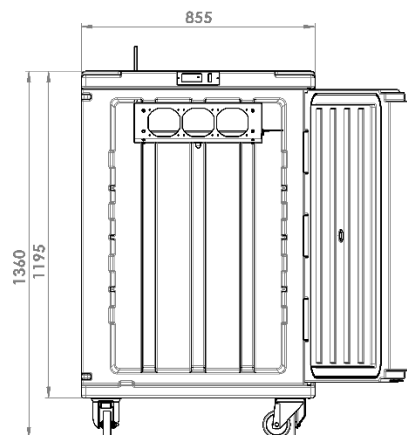
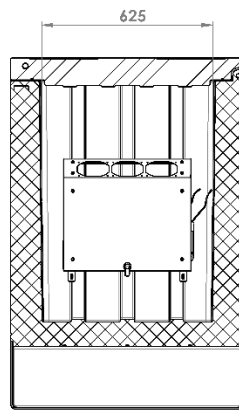



Koala 495 ventilated

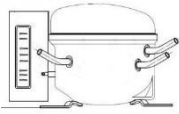

Via Savigliano 34 - 12030 Monasterolo di Savigliano (CN) -ITALY
 Phone +39 0172812600 - info@melform.com
www.melform.com

FEATURES REFRIGERATION UNIT

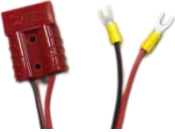
| | | | |
|---|---|--|---|
|  | Static cooling unit version for greater temperature uniformity inside the container |  | Ventilated cooling unit version to ensure a greater speed of reaching the temperature inside the container |
|  | Hermetic compressor with electronic control unit for regulation and control equipped with surge protection |  | Guaranteed refrigeration unit performance for ambient T-use: +10°C to +30°C Container (isothermal body) guaranteed for use: -30° C to +100°C |
|  | 230Vac 50-60Hz cables power supply (standard equipment) |  | Cables for 12Vdc power supply with Anderson terminals (standard equipment) |
|  | Cables for 12Vdc power supply with Anderson terminal on the KOALA side and fork terminal for connection to the vehicle battery (standard equipment) | | |





Degree of accuracy: **+/-0.5 °C**

Refrigerant gas: **R134a (versions 0°C +10/+40°C);**

R452a (versions -25°C +10/+40°C);

Overall heat transfer coefficient: **K=0.35 W/m²K**

PRODUCT FEATURES

| | | | |
|---|---|--|---|
|  | Stainless steel closing handle with release button; Prepared for the use of tamper-evident system |  | Stainless steel rod with 2 hooks integrated in the door |
|  | Temperature regulation and control with programmable digital thermostat |  | USB datalogger available (on request) to record temperature data during transport |
|  | RFID systems for traceability | | |

| Model | Product code | Absorption nominal | Fuses | |
|---|------------------------------|--|--------------------------------|-----------|
| Koala 495 Integrated cooling unit, static 0°C to +10°C | K495AFISDYM0 K495AFISDYM1 | 0.62A at 230Vac 12A to 12Vdc (150 W) | 4A for 230Vac 25A for 12Vdc | |
| Koala 495 Integrated cooling unit, ventilated -25°C to 10°C | K495AFIVBYM0 K495AFIVBYM1 | 1A at 230Vac 25A at 12Vdc (300 W) | 4A for 230Vac 30A for 12Vdc | |
| Koala 495 Integrated cooling unit, static 0°C to +40°C | K495AFISDZM0 K495AFISDZM1 | 0.62A at 230Vac 12A to 12Vdc (150 W) | 4A for 230Vac 25A for 12Vdc | |
| Koala 495 Integrated cooling unit, ventilated -25°C to +40°C | K495AFIVBZM0 K495AFIVBZM1 | 1A at 230Vac 25A at 12Vdc (300 W) | 4A for 230Vac 30A for 12Vdc | |
| ACCESSORIES | Amperage | Weight (Kg) | Dim. (mm) | Code |
| Floor/vehicle fixing kit (for Basic version) | | | | RRI223 |
| Stainless Steel Grid | | 4,7 | 643x835xh16 | AEA046 |
| Card holder | | 0,05 | A5 | RRI141 |
| Power bank charger 12V for KOALA | 100 Ah | 22 | 345x315xh340 | ePB100A01 |
| Power bank charger 12V for KOALA | 120 Ah | 26 | 345x315xh340 | ePB120A01 |
| Power bank charger 12V for KOALA | 150 Ah | 28 | 345x315xh340 | ePB150A01 |
| USB Data Logger Range -30°C +70°C | | | | AFG007 |

