



## Self-powered refrigerated container with removable battery

- Available in versions:
  - **AF: with temperature adjustment range between -18°C and +10°C;**
  - **AFH: with heating kit and temperature adjustment range between -18°C and +40°C.**
- Available with 65Ah or 100Ah battery LiFePO4.
- The battery can be recharged connecting Koala Green to the usual 230Vac main power for about 8/10 hours. In alternative, a practical counter allows to remove the battery from the cooling unit and recharge it with a dedicated external power supply.
- The battery LiFePO4 stores the energy necessary for the power supply of cooling unit. Once recharged, the battery gives the container autonomy. The autonomy duration depends on the battery amperage, the features of the refrigerated container, the size of the load, the temperature setting and the ambient temperature.
- The insulation provided by the container walls guarantees the temperature maintenance with a minimum number of ignitions of the cooling unit and this helps to limit the energy consumption.
- In the positive versions the static cooling unit ensures a reduced electricity consumption. In the negative versions, the ventilated cooling unit ensures a faster and more uniform temperature achievement inside the container.
- The cooling unit comes into operation when the internal temperature is higher than the temperature set by programmable digital thermostat. This allows the temperature to be maintained at a constant level, even at very cold external temperatures.
- In AFH versions the cooling unit starts working when the internal temperature is lower than the temperature set by the programmable digital thermostat. This allows to keep the temperature constant even in very cold external temperatures.
- Total maintenance of the required temperature at all stages of transport.
- Equipped with a low-consumption cooling unit.
- It can be powered at 230Vac using normal main power.
- Manufactured using the rotational moulding technology: mono-block container and door (free of sharp edges, joints and welds).
- **Fully recyclable** at the end of its operation life.



## MANUFACTURING MATERIALS

<b>Polyethylene</b>	inner and outside walls of the container and the door; suitable for food contact.	<b>Polyurethane</b>	insulating material between the walls of the container and of the door, free of CFC and HCFC
<b>Silicone rubber</b>	gasket	<b>Polyamide and rubber</b>	castors (rubber tread and polyamide core)
<b>Galvanized steel</b>	crankcase, hinge rods, hinge rods connection plates castors support	<b>Stainless steel</b>	handling handles, locking handle, internal door rod
<b>Polypropylene</b>	hinges		

## TECHNICAL FEATURES

<b>AF model</b>	<ul style="list-style-type: none"> <li>• 0°C +10°C</li> <li>• -18°C +10°C</li> </ul>	<b>AFH model</b>	<ul style="list-style-type: none"> <li>• 0°C +40°C</li> <li>• -18°C +40°C</li> </ul>
<b>+/- 0,5 °C</b>	Degree of accuracy in temperature control: <b>+/-0,5 °C</b>		Performance of the cooling unit guaranteed for use at ambient temperature: <b>from +10°C to +30°C</b>  Container (insulated case) guaranteed for use: <b>from -30°C to +100°C</b>
<b>GAS</b>	<ul style="list-style-type: none"> <li>• <b>R134a</b> (version 0°C +10/+40°C)</li> <li>• <b>R452A</b> (versions -18°C +10/+40°C)</li> </ul>		Equipped with cable for power supply to <b>230Vac</b> 50-60Hz of the cooling unit and for recharging the battery.
	Hermetic compressor with electronic control unit for adjustment and control equipped with overvoltage protections.		Adjustment and control of the temperature with programmable digital thermostat.
	Removable battery for easy replacement and recharging with external power supply.		Battery indicator displays: <ul style="list-style-type: none"> <li>• Battery voltage (V)</li> <li>• Input/output current (A)</li> <li>• Input/output power (W)</li> <li>• Amperhours (Ah) consumed</li> <li>• Charging status (%)</li> <li>• Remaining autonomy (h)</li> </ul>
	Static versions equipped with a static evaporator "roll-bond"  Lower energy consumption compared to the version with ventilated refrigeration unit.		In the ventilated versions, the ventilation system ensures a faster and more uniform temperature achievement inside the container.
	USB datalogger available on request to record temperature data during transport.		EVlink module with Bluetooth interface available on request.

## TECHNICAL FEATURES

	<p>3 seats for housing of grids positioned to 335/500/665 mm from the bottom of the container. Grids available on request.</p>		<p>Label holder for identification of contents or destination on request. Suitable for documents A5 format</p>
	<p>Stainless steel locking handle with release button; it is prepared for the use of tamper-proof system</p>		<p>Mono-block structure, no sharp edges, joints and welds</p>
	<p>Internal grooves improving good air circulation.</p>		<p>Door opens up to 270° with door retaining catch</p>
	<p>Easily removable door seal</p>		<p>Stainless steel rod with 2 hooks integrated inside the door</p>
	<p>4 rubber coated castors of 100 mm diameter (2 fixed and 2 swivel of which one equipped with brake) Support runners plate integrated in the container</p>		<p>Available also in versions:</p> <ul style="list-style-type: none"> <li>- Pallet with galvanised steel frame at 4 feet of 120 mm</li> <li>- 4 feet in galvanised steel h 130mm</li> </ul>
<p><b>K</b></p>	<p>Overhall heat transmission coefficient: <b>K=0,32 W/m²K</b></p>		<p>Insulated with CFC and HCFC free polyurethane foam</p>

**TECHNICAL SPECIFICATIONS**

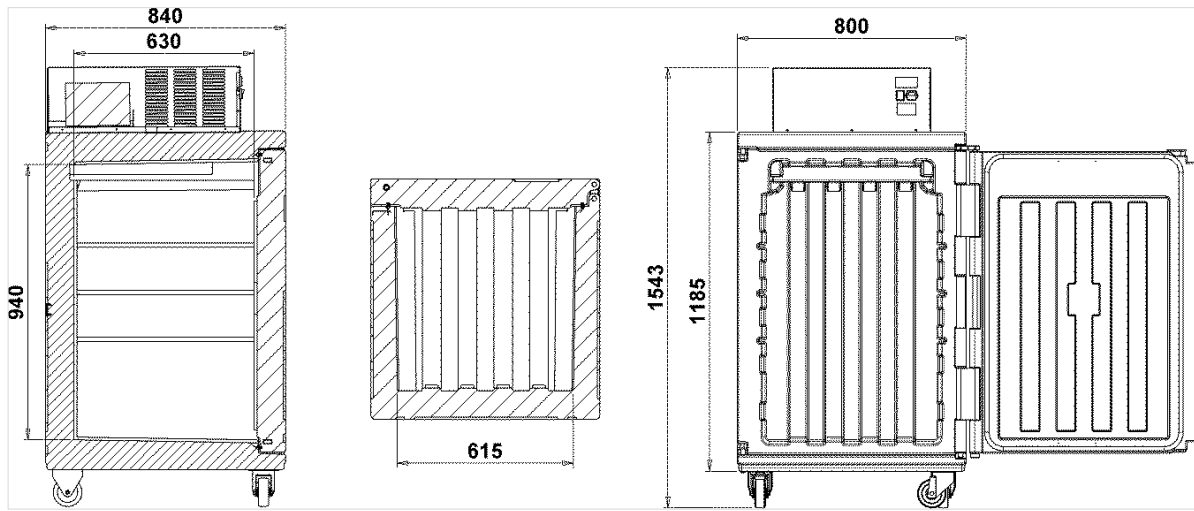

**Model with cooling unit on top positive static**

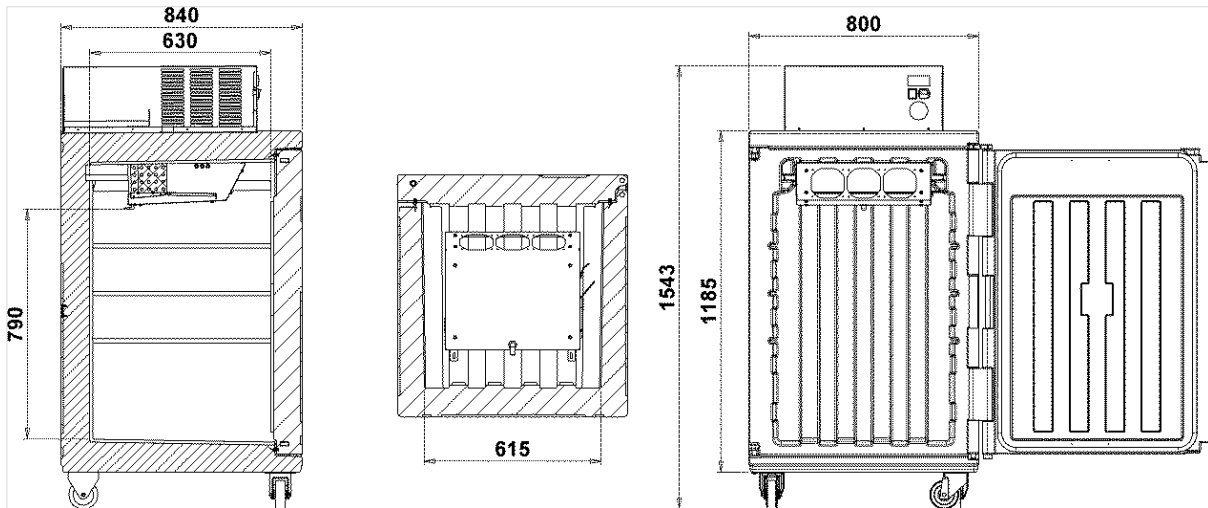

**Model with cooling unit on top negative ventilated**

MODEL	Code	Nom. Absorption to 230Vac [A]	Fusible 230Vac [A]	External dim. [mm]	Internal dim. [mm]	Weight [kg]
<b>AF VERSION</b>						
Koala Green 370 AF <b>Cooling unit on top static</b> 0°C +10°C	K370AFTSDYM1	<b>0,62A</b>	<b>4A</b>	800x840xh1543	615x630xh940	<b>85.5</b>
Koala Green 370 AF <b>Cooling unit on top ventilated</b> -18°C +10°C	K370AFTVCYM1	<b>1A</b>	<b>4A</b>	800x840xh1543	615x630xh790	<b>95.5</b>
<b>AFH VERSION (with heating kit)</b>						
Koala Green 370 AFH <b>Cooling unit on top static</b> 0°C +40°C	K370AFTSDZM1	<b>0,62A</b>	<b>4A</b>	800x840xh1543	615x630xh940	<b>85.5</b>
Koala Green 370 AFH <b>Cooling unit on top ventilated</b> -18°C +40°C	K370AFTVCZM1	<b>1A</b>	<b>4A</b>	800x840xh1543	615x630xh790	<b>95.5</b>
<b>BATTERY</b>						
	<b>Code</b>	<b>Weight [kg]</b>				
Battery 65Ah	EPKIT65	9.5				
Battery 100 Ah	EPKIT100	14.5				
<b>ACCESSORIES</b>						
	<b>Code</b>	<b>External dim. [mm]</b>	<b>Internal dim. [mm]</b>	<b>Weight[kg]</b>		
Label holder	AMC101	173xh200	148xh210 -A5-			
Stainless steel grid	AEA018	650x610xh16		3,85		
Additional battery kit 65Ah	BATT65AH					
Additional Battery kit 100Ah	BATT100AH					
Battery charger 10A	CHARGER10A					



Via Savigliano 34 - 12030 Monasterolo di Savigliano (CN)  
 Tel. +39 0172812600 - Fax +39 017285991 - info@melform.com  
[www.melform.com](http://www.melform.com)